

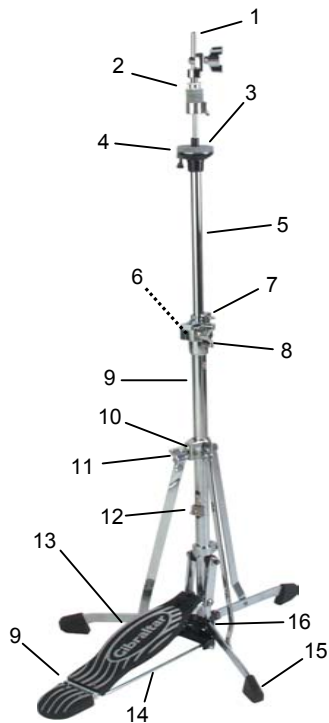

8600 Series Hardware

KAMAN
music corporation

Check out the entire line of
Gibraltar Hardware products at ...
www.GibraltarHardware.com



Hi-Hat Stand Setup Instructions

- A)** Remove cardboard and plastic cover from pedal board and attach the radius rod (GP-0021) to the frame.
- B)** Unfold and adjust the tripod legs to be flush to the ground and slightly raise the middle frame.
- C)** Screw the upper pull rod (GP-0016) into the lower base pull rod stem.
- D)** Place the upper height adjust tube (GP-6021) into the base and adjust to the desired position. Use the fitted memory lock (GP-6022) on the tube to retain this position.
- E)** Place the bottom hi-hat cymbal onto the hi-hat stand cup felt (SC-HHCF) facing upwards.
- F)** Place the top hi-hat cymbal into the hi-hat clutch (SC-4420S), inserting it between the two small felts on the clutch, then slip it onto the upper pullrod.
- G)** Secure the upper hi-hat cymbal with clutch onto the pull rod leaving approximately 1" spacing between the upper and lower hi-hat cymbals, then adjust to the desired spacing.



Snare Stand Setup Instructions

- A)** Open the tripod base of the snare stand (GP-6083) and place it in an upright position.
- B)** Insert the upper snare tube (GP-6082) into the stand base.
- C)** Open the snare basket (GP-6051) to fit the snare drum to be used.
- D)** Once the snare drum is placed in the basket, tighten the basket to secure the drum. Be aware that over tightening the basket may choke the drum sound, limiting the response.

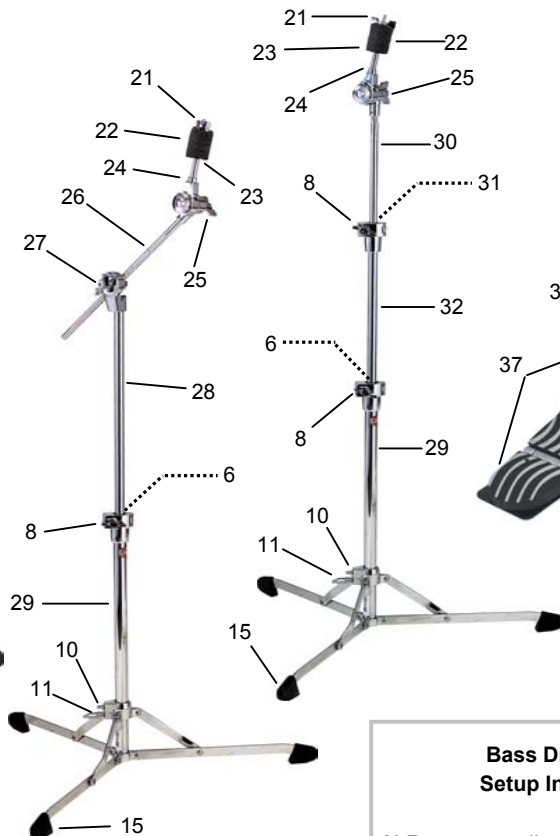

Cymbal Stand Setup Instructions

- A)** Open the tripod stand base (GP-6087) of the cymbal stand and place it in an upright position.
- B)** Insert the upper cymbal tube into the stand base.
- C)** Insert the boom arm, 8609 only, into the upper tilter eyebolt assembly.
- D)** Use the tilter on the upper height adjust tube and, or, the boom arm to position your cymbal to the desired angle.

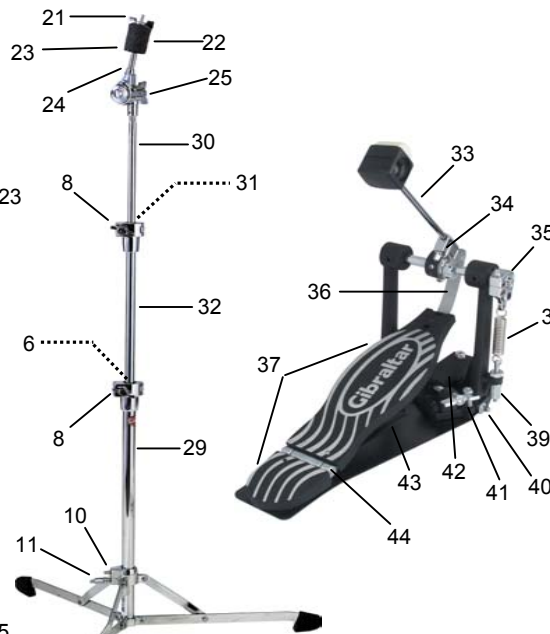

Bass Drum Pedal Setup Instructions

- A)** Remove cardboard and plastic wrap from the pedal board.
- B)** Insert the beater (SC-DSAB) into the beater holder (GP-6000) and adjust it to your desired height.
- C)** Insert the pedal spring cam (GP-6002) onto the knurled hub that is on the axle.
- D)** To adjust the spring tension to your desired response, loosen both upper and lower finger nuts to increase or decrease the tension, then re-tighten the finger nuts.
- E)** Slide the pedal frame onto the bass drum hoop and tighten the hoop clamp (GP-5074) down to the bass drum hoop.
- F)** To avoid pedal slippage and bass drum movement, place the bass drum and pedal onto a carpeted surface.
- G)** Lubricate metal-to-metal contact points periodically to insure smooth operation. We suggest #SC-GLO Gibraltar Pedal Lubricant.

Replacement Part Numbers

- 1 - GP-0016 Upper Pull Rod
- 2 - SC-4420S Super Hi-Hat Clutch
- 3 - SC-HHCF Cup Felt
- 4 - SC-HHFW Flat Washer
- 5 - GP-6021 Upper Height Adjust Tube 5/8"
- 6 - GP-5116 Nylon Inner Sleeve 5/8"
- 7 - GP-6022 Fitted Memory Lock
- 8 - GP-5117 Wing/Short Bolt Set 6mm
- 9 - GP-6023 Lower Base Assembly
- 10 - GP-0121 8mm Key Screw
- 11 - SC-0009 8mm Wing Bolt
- 12 - GP-5171 Spring Tension Assembly
- 13 - GP-5200 Hinged Pedal Board
- 14 - GP-0021 Radius Rod
- 15 - GP-6024 Flat Base Rubber Foot
- 16 - GP-6027 Dual Key Adjust Spike
- 17 - GP-6051 Snare Basket
- 18 - GP-6052 Wing Nut/Bolt Assembly 8mm
- 19 - GP-6082 Upper Snare Stand Tube 5/8"
- 20 - GP-6083 Lower Flat Base Assembly
- 21 - SC-13P2 Wing Nut 8mm
- 22 - SC-CFS/4 Small Cymbal Felt
- 23 - SC-19B Cymbal Sleeve 8mm
- 24 - GP-6084 Brake Tilter Top
- 25 - GP-6085 Brake Tilter Wing Nut/Bolt Set
- 26 - GP-6086 Brake Tilter Boom Arm 10.5mm
- 27 - GP-6040 Eyebolt/Wing Nut Assm.
- 28 - GP-6091 5/8" Upper Height Adjust Tube
- 29 - GP-6087 Flat Cymbal Stand Base
- 30 - GP-6088 Upper Tube 1/2" for 8610 Stand
- 31 - GP-6089 Nylon Inner Sleeve 1/2"
- 32 - GP-6090 Middle Shaft
- 33 - SC-DSAB Dual Surface Beater
- 34 - GP-6000 Beater Holder
- 35 - GP-6002 Spring Rocker Hub
- 36 - GP-15B Replacement Strap
- 37 - GP-5200 Complete Hinged Pedalboard
- 38 - GP-5096 Spring Assembly
- 39 - GP-5103 Spring Tension Assembly
- 40 - GP-5242 Rock Plate Screw Kit
- 41 - GP-0020 Anchor Screw Assembly
- 42 - GP-5074 Hoop Clamp Assembly
- 43 - GRP2 - 3 Hole Rock Plate
- 44 - SC-2000 Pedal Hinge Assembly